

DCBS



DC-HR12160W

Valve-regulated lead-acid battery

HIGH RATE SERIES

Characteristics

Nominal voltage	12V (6 cell per unit)	
Nominal power at 15 min. rate 1.67V/cell (25°C)	160W	
Capacity (25°C)	10 Hours rate/10.8V	45Ah
	5 Hours rate/10.8V	39.3Ah
Terminal type	T14	
Torque	5.1±0.6N.m	
Approx. internal resistance (25°C)	7.0 mΩ	
Dimensions	Length	197±2mm (7.76inch)
	Width	165±2mm (6.50inch)
	Height	170±2mm (6.69inch)
	Total height	170±2mm (6.69inch)
Design Life (stand-by)	JIS at 25°C	10 years
	Eurobat at 20°C	10-12 years
Weight	14.30kg (31.50lbs)±3%	
Nominal operating temperature	25±3°C (77°F±5)	
Operating temperature range	Discharge	-15°C~50°C (5°F~122°F)
	Charge	-10°C~50°C (14°F~122°F)
	Storage	-20°C~50°C (-4°F~122°F)
Float charging voltage at 25°C	13.5V~13.8V	
Cyclic charging voltage at 25°C	14.5V~15.0V	
Temperature compensation	Float charge	-18 (mV/°C/Block)
	Cycle charge	-30 (mV/°C/Block)
Max. charging current (A)	12.80A	
Max. discharge current for 5 seconds	400A	
Self discharge rate (25°C)	≤3%/month	
Battery container ABS UL94-HB	V-0 optional	

Overview

High Rate series batteries are specially de-signed for applications that require high power output. With their high-power density and low internal resistance, the HR series are the right choice for your most demanding applications.

Dimensions & Terminal Type (mm)

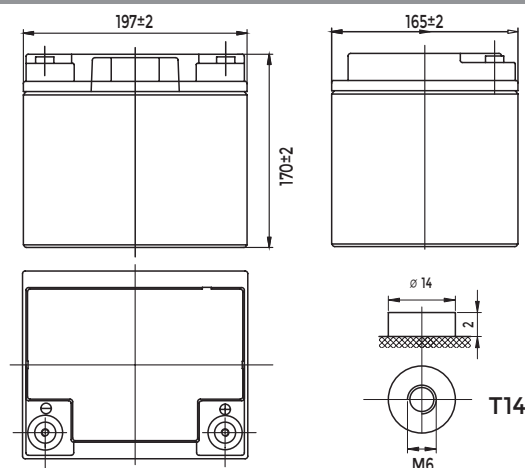

Construc tion

Component	Positive Plate	Negative plate	Container	Separator	Electrolyte	Safety valve	Terminal
Raw material	Lead dioxide	Lead	ABS (V-0 opt.)	AGM	Sulfuric Acid	Rubber	Copper

Constant current discharge characteristics at 25°C

(Ampere/cell)

F.V/Time	10min	15min	20min	30min	45min	60min	2h	3h	4h	5h	6h
1.60V/cell	111.38	91.57	69.08	48.88	36.10	29.40	16.40	11.80	9.50	8.26	7.07
1.67V/cell	107.10	88.79	66.26	47.37	34.90	28.70	16.30	11.70	9.42	8.19	7.01
1.70V/cell	103.99	86.00	64.94	46.46	34.30	28.30	16.20	11.60	9.38	8.16	6.98
1.75V/cell	99.60	83.11	62.72	45.35	33.40	27.70	16.00	11.60	9.32	8.10	6.93
1.80V/cell	93.93	78.72	59.39	43.63	32.20	26.80	15.60	11.20	9.04	7.86	6.72

Constant power discharge characteristics at 25°C

(Watts/cell)

F.V/Time	10min	15min	20min	30min	45min	60min	2h	3h	4h	5h	6h
1.60V/cell	203.91	166.65	132.00	94.44	69.60	56.80	32.10	23.20	18.70	16.40	14.00
1.67V/cell	195.59	160.00	127.00	91.41	67.40	55.40	31.80	23.00	18.60	16.20	13.90
1.70V/cell	190.39	156.55	124.00	89.69	66.20	54.50	31.60	22.90	18.50	16.20	13.80
1.75V/cell	182.07	151.50	120.00	87.47	64.60	53.50	31.10	22.80	18.40	16.00	13.70
1.80V/cell	171.66	143.42	113.00	84.34	62.20	51.80	30.30	22.10	17.80	15.60	13.30

The above characteristics represent average values and can be obtained within three charge and discharge cycles. The batteries must be fully charged before testing. The data in this document is subject to change without notice and become contractual only after written confirmation. Please contact DCBS for the latest available version.

DC-HR12160W

Valve-regulated lead-acid battery

HIGH RATE

SERIES

Discharge characteristics (25°C)

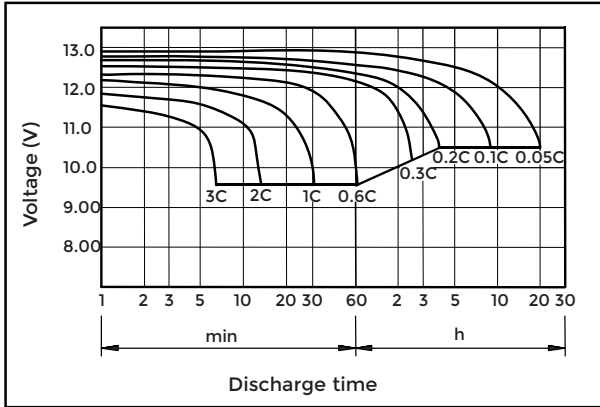

Charging characteristics (25°C)

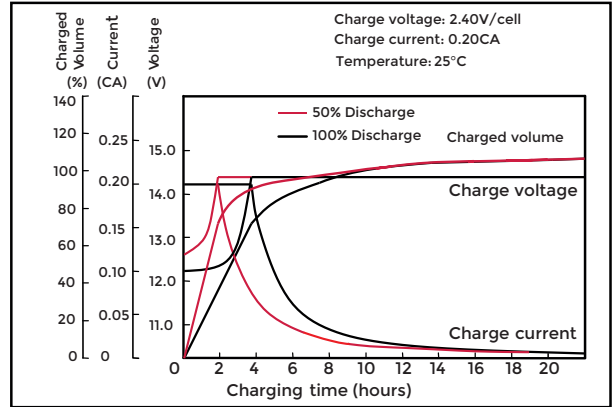

Temperature effects on capacity

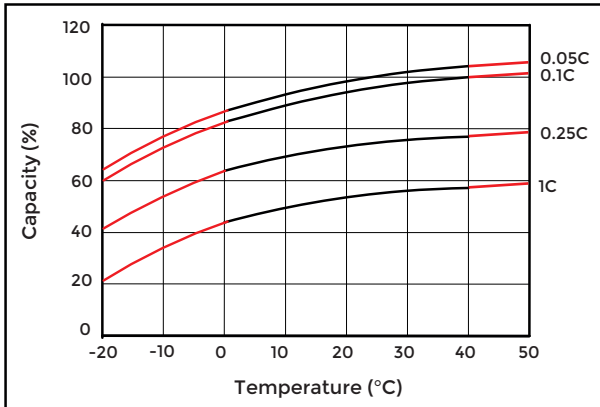

Self-discharge characteristics

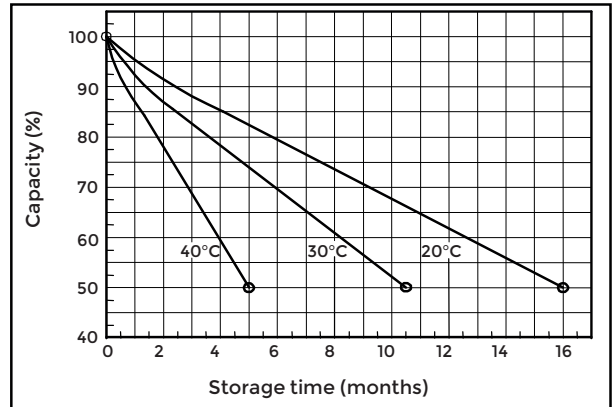

Floating life on temperature

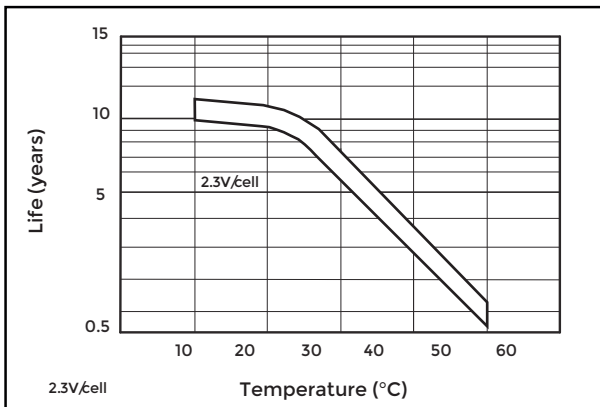

Cycle life on D.O.D (25°C)

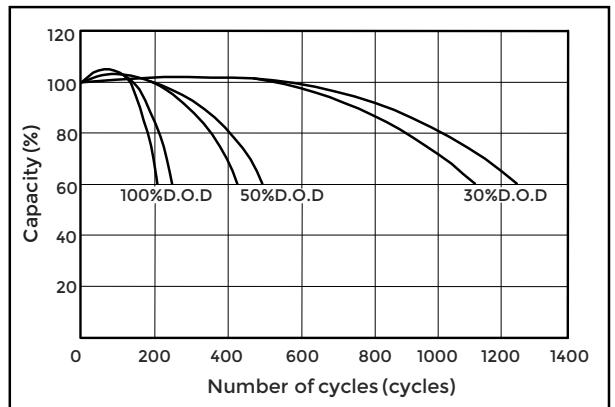

Relationship for OCV and capacity (25°C)

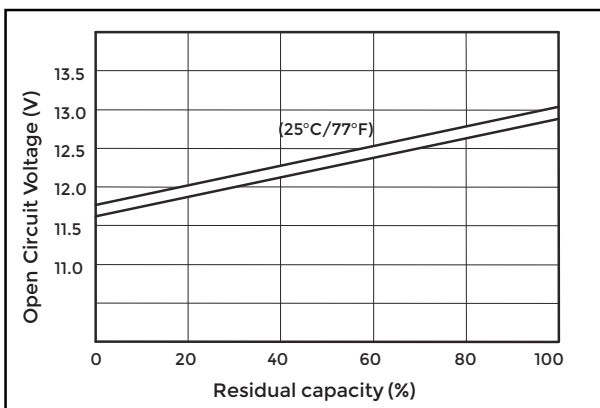

Charging voltage VS temperature

