



DC-HR1221W

Valve-regulated lead-acid battery

HIGH RATE SERIES

Characteristics

Nominal voltage	12V (6 cells per unit)	
Nominal power at 15 min. rate 1.67V/cell (25°C)	21W	
Capacity (25°C)	20 Hours rate/10.5V	5Ah
	5 Hours rate/10.5V	4.45Ah
Terminal type	T1/T2	
Torque	N/A	
Approx. internal resistance (25°C)	27.0 mΩ	
Dimensions	Length	90±1mm (3.54inch)
	Width	70±1mm (2.76inch)
	Height	101±1mm (3.98inch)
	Total height	107±1mm (4.21inch)
Design Life (stand-by)	JIS at 25°C	5 years
	Eurobat at 20°C	3-5 years
Weight	1.62kg (3.57lbs)±4%	
Nominal operating temperature	25±3°C (77°F±5)	
Operating temperature range	Discharge	-15°C~50°C (5°F~122°F)
	Charge	-10°C~50°C (14°F~122°F)
	Storage	-20°C~50°C (-4°F~122°F)
Float charging voltage at 25°C	13.6V~13.8V	
Cyclic charging voltage at 25°C	14.5V~15.0V	
Temperature compensation	Float charge	-18 (mV/°C/Block)
	Cycle charge	-30 (mV/°C/Block)
Max. charging current (A)	1.68A	
Max. discharge current for 5 seconds	75A	
Self discharge rate (25°C)	≤3%/month	
Battery container ABS UL94-HB	V-0 optional	

Overview

NPP Power High Rate series batteries are specially designed for applications that require high power output. With their high-power density and low internal resistance, the HR series are the right choice for your most demanding applications.

Dimensions & Terminal Type (mm)

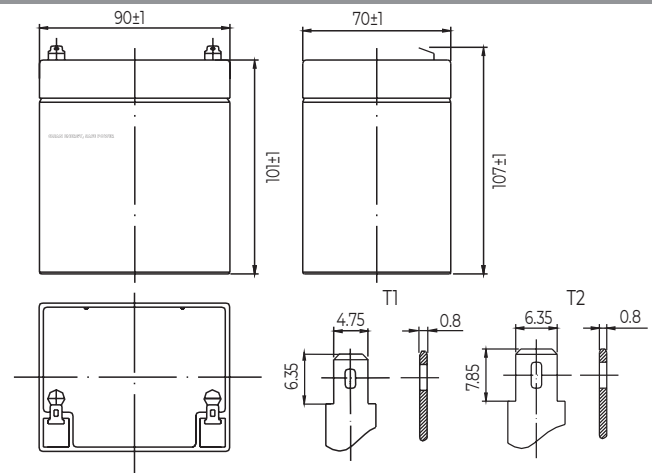

Construction

Component	Positive Plate	Negative plate	Container	Separator	Electrolyte	Safety valve	Terminal
Raw material	Lead dioxide	Lead	ABS (V-0 opt.)	AGM	Sulfuric Acid	Rubber	Copper

Constant current discharge characteristics at 25°C

(Ampere/cell)

F.V/Time	5min	10min	15min	20min	30min	45min	60min	2h	3h	4h	5h
1.60V/cell	25.14	15.44	11.33	9.06	6.20	4.37	3.58	1.84	1.31	1.05	0.90
1.67V/cell	23.92	14.77	10.92	8.69	6.00	4.23	3.49	1.82	1.29	1.04	0.89
1.70V/cell	23.37	14.33	10.61	8.52	5.89	4.15	3.43	1.81	1.29	1.04	0.89
1.75V/cell	22.38	13.78	10.30	8.23	5.74	4.05	3.36	1.78	1.28	1.03	0.89
1.80V/cell	21.06	13.01	9.79	7.79	5.53	3.90	3.26	1.74	1.24	1.00	0.86

Constant power discharge characteristics at 25°C

(Watts/cell)

F.V/Time	5min	10min	15min	20min	30min	45min	60min	2h	3h	4h	5h
1.60V/cell	45.91	28.56	22.45	17.89	12.29	8.65	7.08	3.66	2.62	2.11	1.81
1.67V/cell	43.81	27.30	21.00	17.26	11.87	8.38	6.90	3.62	2.60	2.09	1.80
1.70V/cell	42.66	26.57	21.12	16.85	11.66	8.22	6.80	3.60	2.59	2.08	1.79
1.75V/cell	40.87	25.41	20.39	16.33	11.34	8.02	6.66	3.55	2.57	2.07	1.78
1.80V/cell	38.56	23.94	19.26	15.39	10.92	7.73	6.46	3.46	2.50	2.01	1.73

The above characteristics represent average values and can be obtained within three charge and discharge cycles. The batteries must be fully charged before testing. The data in this document is subject to change without notice and become contractual only after written confirmation. Please contact NPP Power for the latest available version.

Discharge characteristics (25°C)

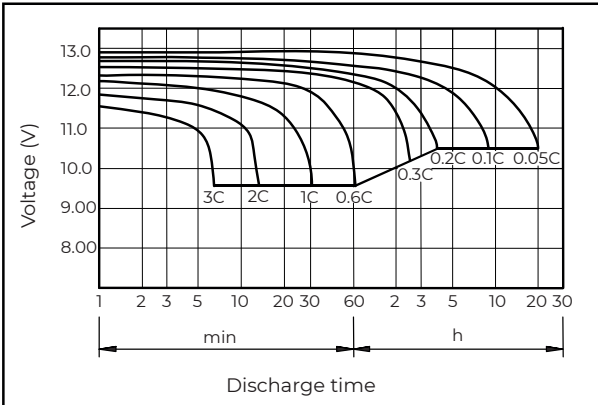

Charging characteristics (25°C)

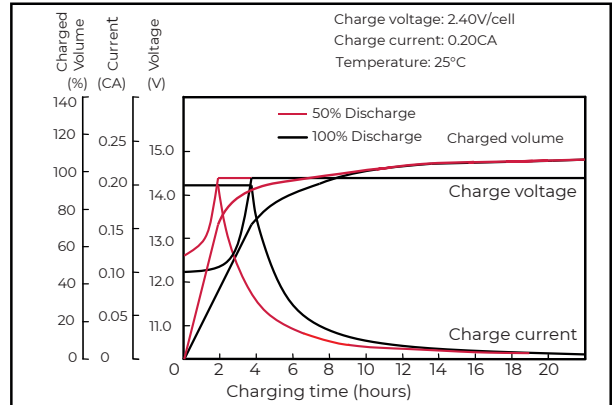

Temperature effects on capacity

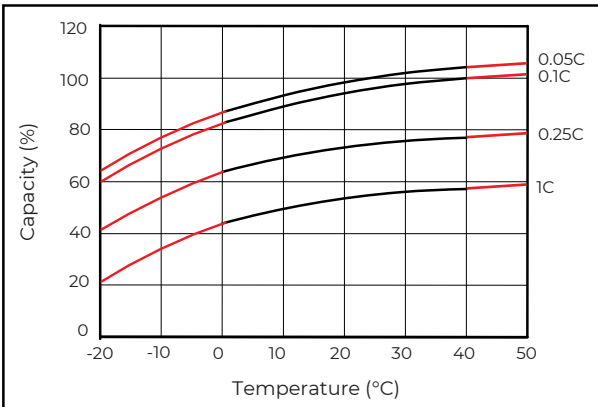

Self-discharge characteristics

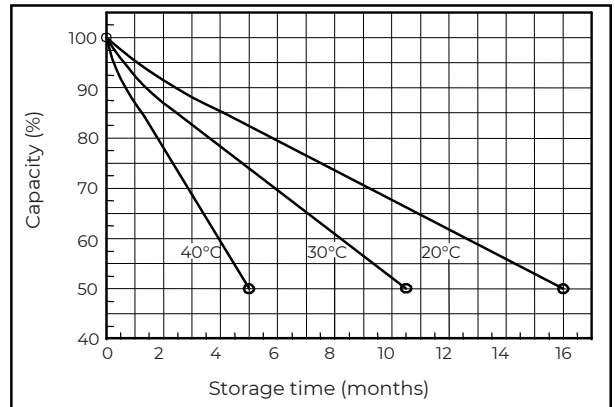

Floating life on temperature

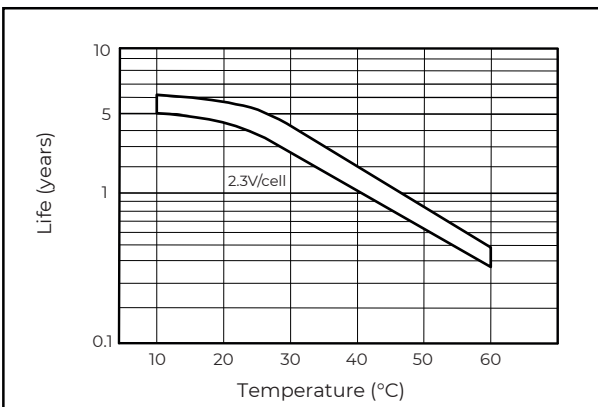

Cycle life on D.O.D (25°C)

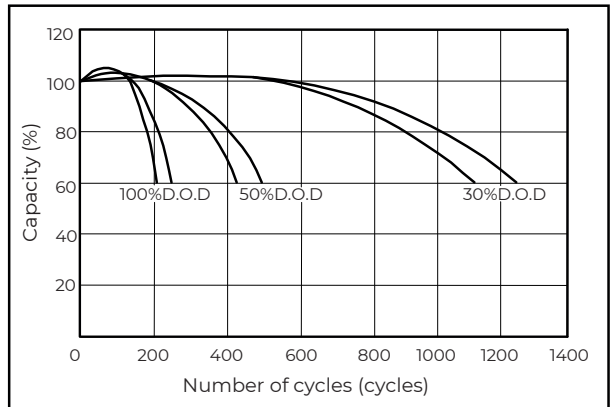

Relationship for OCV and capacity (25°C)

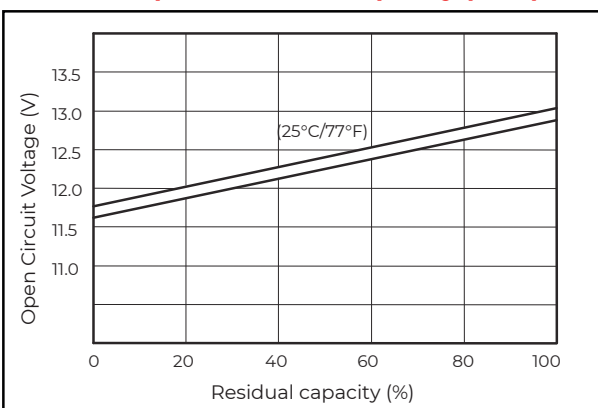

Charging voltage VS temperature

